

GULLWING DOOR HINGES

WELD PLATE

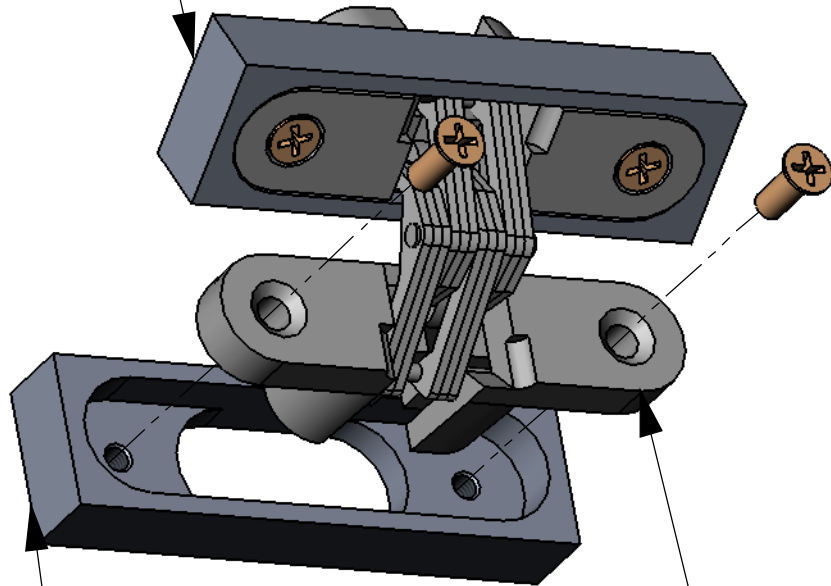

HINGE ASSEMBLY

WELD PLATE

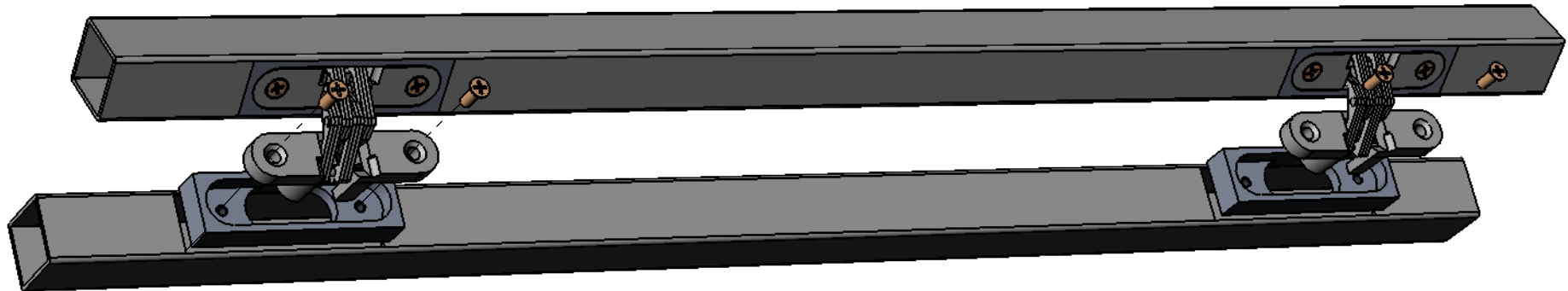

GAS STRUT DIMENSIONS

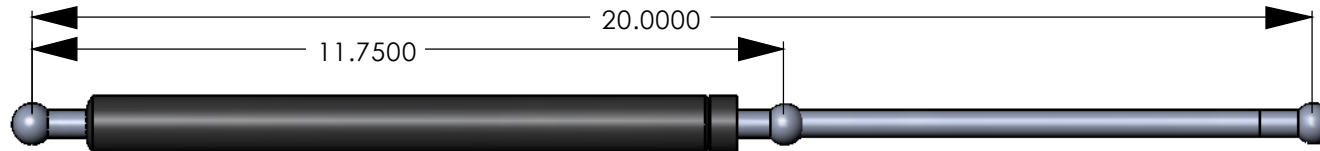

Installation

1. Disconnect Battery
2. Remove the door panel and disconnect any wires running from the door to the door jamb
3. Remove the door from the car. Determine the balance point for the door by carefully laying the door on top of a small piece of tubing or pipe. The tubing should run vertically under the door. Move the door side to side to determine the balance point of the door. Mark this point on the top jamb of the door.
4. Hinges should be mounted equal distance from the balance point found in the previous step. The hinges need to be perfectly parallel in order for the door to open properly. Using the supplied template mark where the hinges are going to be mounted.
5. Reinforce all metal around the hinge with box tubing or with heavier gauge sheet metal.
6. Cut out the area in the template so the weld plate can sit flush in the door jamb.
7. Tack weld the weld plate into the door.
8. Transfer the hinge locations from the door to the door jamb and repeat steps 5 -7 on the door jamb.
9. Install the hinge assemblies into the weld plates and install the door. Test the hinges by opening and closing the door.
10. When door opens and closes smoothly remove the door and take the hinge assemblies out of the weld plates. Next weld the weld plates completely to the car.
11. Reinstall the door.
12. Mount the gas strut. The strut should be completely compressed when the door is closed. Mount the strut as close to the bottom of the door as possible. Material may need to be removed from the door jamb and the door to allow clearance for the strut when the door is closed.